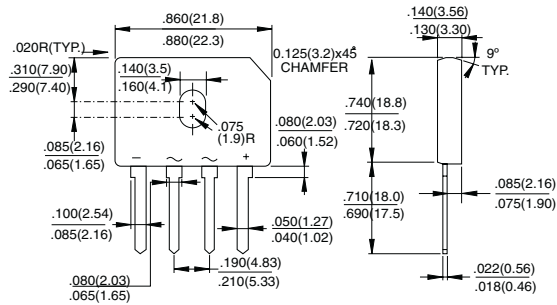

8.0 Amp. Glass Passivated Bridge Rectifiers

Dimensions in mm.	GBU	Voltage 400 V to 1000 V	Current 8.0 A
			<ul style="list-style-type: none"> Plastic material has Underwriters Laboratory Flammability Classification 94V-0 Ideal for printed circuit board Reliable low cost construction High case dielectric strength of 1500VRMS High temperature soldering guaranteed: 260 °C / 10 seconds / .375", (9.5mm) lead lengths at 5 lbs., (2.3Kg) tension Surge overload rating to 200 amperes peak

Maximum Ratings and Electrical Characteristics at 25 °C

		GBU 804G	GBU 805G	GBU 806G	GBU 807G
V_{RRM}	Maximum Recurrent Peak Reverse Voltage (V)	400	600	800	1000
V_{RMS}	Maximum RMS Voltage (V)	280	420	560	700
V_{DC}	Maximum DC Blocking Voltage (V)	400	600	800	1000
$I_{F(AV)}$	Maximum Average Forward Rectified Current @ $T_C = 60\text{ °C}$ (Note 1) @ $T_A = 25\text{ °C}$ (Note 2)	8.0 A 3.0 A			
I_{FSM}	Peak Forward Surge Current, 8.3 ms Single Half Sine-wave Superimposed on Rated Load (JEDEC Method)	200 A			
C_j	Typical Junction capacitance per leg (Note 3)	211pF	94pF		
T_j	Operating Temperature Range	-55 to +150 °C			
T_{stg}	Storage Temperature Range	-55 to +150 °C			

Electrical Characteristics at $T_{amb} = 25\text{ °C}$

V_F	Maximum Instantaneous Forward Voltage drop per leg @ = 4.0 A	1.0 V
I_R	Maximum DC Reverse Current @ $T_A = 25\text{ °C}$ at Rated DC Blocking Voltage @ $T_A = 125\text{ °C}$	5.0 μ A 500 μ A
$R_{th(j-a)}$	Typical Thermal Resistance per leg (Note 1)	20 °C/W
$R_{th(j-c)}$	(Note 2)	4.0 °C/W

Notes: 1. Mounted on P.C.B. with 0.5" x 0.5" (13mm x 13mm) Copper Pads and 0.375" 9.5mm) Lead Length.
 2. Mounten on Al. Plate of 2" x 3" x 0.25" Al-Plate Heatsink.
 3. Measured at 1.0MHZ and Applied Reverse Voltage of 4.0 Volts.

Rating And Characteristic Curves

FIG.1- MAXIMUM FORWARD CURRENT DERATING CURVE

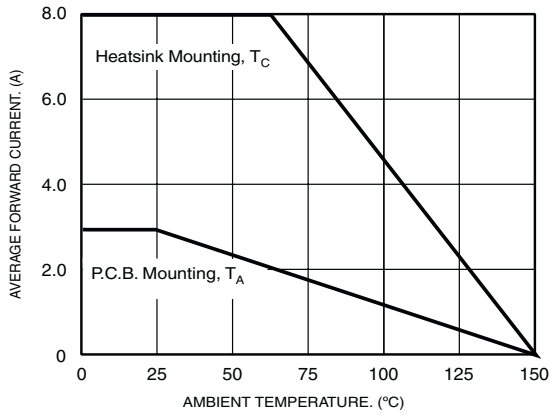

FIG.2- TYPICAL REVERSE CHARACTERISTICS PER BRIDGE ELEMENT

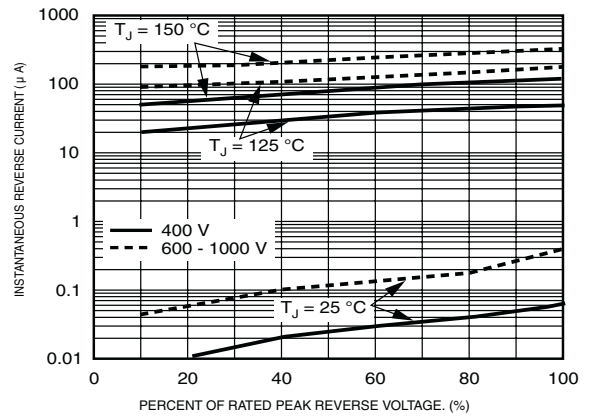

FIG.3- MAXIMUM NON-REPETITIVE FORWARD SURGE CURRENT PER BRIDGE ELEMENT

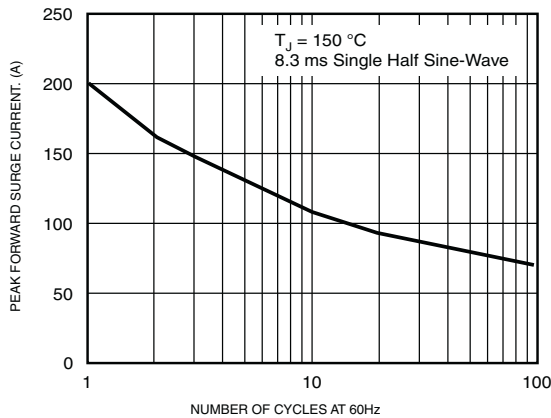

FIG.4- TYPICAL JUNCTION CAPACITANCE

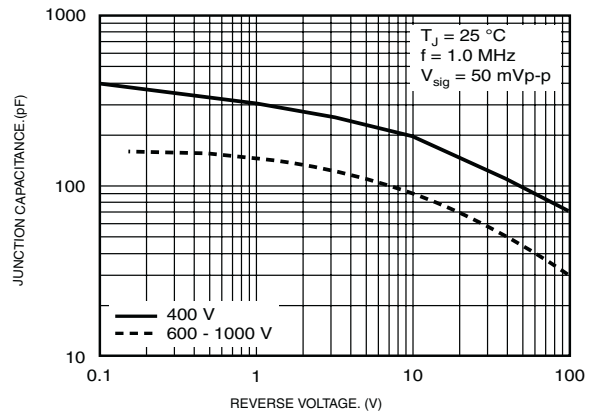

FIG.5- TYPICAL FORWARD CHARACTERISTICS PER BRIDGE ELEMENT

